



PWA: ASSY., PWA, POWER

ASSEMBLY: 03-925082-01

DATE: SEPT. 19, 1997

REV: 4

Sheet: 2 of 3

<u>Item</u>	<u>Ref Designator</u>	<u>Qty</u>	<u>Part Number</u>	<u>Part Description</u>
1		1	03-925083-01	FAB,PWA,POWER
2	AR1-2	2	62-603400-00	IC,LM393AD,DUAL-COMPARATOR,SMT
3	C1	1	41-264470-00	CAP, .05UF,500V,+80-20%,CER
4	C2-4	3	41-506159-00	CAP,6800UF,50V,AL
5	C5-6	2	41-503939-00	CAP,2200UF,35V,20%,AL,LOW_ESR
6	C7-8, C10-12, C16-21	11	41-802301-00	CAP,0.1MF,50V,10%,CER,SMT
7	C9	1	41-304310-00	CAP,47UF,20V,20%,TA,SMT
8	C13, C15	2	41-264465-00	CAP,0.01UF,1KV,-20+80%,CER
9	C22-29	8	41-801102-00	CAP,CHIP,220PF,100V,5%,CER,COG
10	CR1	1	66-230696-00	DIODE_BRIDGE,35A,100V,GBPC35-01W
11	CR2-4	3	66-999964-00	DIODE,RLR4002,100V,.8A,SMT
12	F1-2, F4	3	55-500334-00	FUSE,6.3A,250V,TYPE_T,5MM
13	F3	1	55-500348-00	FUSE,10A,250V,TYPE_F,5MM
14	HS1-7	7	66-899999-00	HEATSINK,T0-220,TH6070B-MT-SF1
15	HS8-9	2	03-925265-01	HEATSINK,T0-220
16	J40	1	51-210300-00	CONN,40PIN,HEADER,RIBBON
17	J41	1	51-406946-00	CONN,14PIN,PC,.165,AMP
18	J42	1	51-408926-00	CONN,8_PIN,PC,.2
19	J43	1	51-408924-00	CONN,6_PIN,PC,.2
20	J44	1	51-406938-00	CONN,6PIN,PC,.165,AMP
21	J45-46	2	51-190331-00	CONN,2PIN,PC,.165,RT.,MOLEX
22	J47	1	51-406947-00	CONN,18PIN,PC,.165,AMP
23	J48	1	51-406855-00	CONN,2PIN,PC,.44,AMP
24	J49	1	51-406856-00	CONN,3PIN,PC,.44,AMP
25	J50	1	51-406857-00	CONN,5PIN,PC,.44,AMP
26	J51	1	51-411149-00	CONN,4PIN,PC,.1
27	K1	1	72-130115-00	RELAY,CONTACTOR,30A,120/277V
28	Q1	1	66-650049-00	TRIAC,400V,40A,MAC224A
29	Q2-8	7	66-650003-00	TRIAC,400V,8A,SC142D
30	Q10	1	62-990710-00	XSTR,NPN,MMST3904,40V,SMT
31	R1-8	8	31-403189-00	RES,MF,562,1/8W,1%,100PPM,SMT
32	R9-16	8	31-403174-00	RES,CHIP,392,1/8W,1%,100PPM
33	R17, R29	2	31-411038-00	RES,CHIP,39,1/2W,5%,300PPM
34	R18, R30, R32, R40, R42, R44	6	31-403309-00	RES,MF,10.0K,1/8W,1%,100PPM,SMT
35	R19	1	31-403338-00	RES,CHIP,20K,1/8W,1%,100PPM
36	R20, R22	2	31-403276-00	RES,CHIP,4.53K,1/8W,1%,100PPM
37	R24	1	31-403228-00	RES,1.43K,1/8W,1%,100PPM,SMT
38	R25	1	31-403209-00	RES,909,1/8W,1%,100PPM,SMT
39	R28, R39, R47	3	31-403501-00	RES,CHIP,1.00M,1/8W,1%,100PPM

PWA: ASSY., PWA, POWER

ASSEMBLY: 03-925082-01

DATE: SEPT. 19, 1997

REV: 4

Sheet: 3 of 3

<u>Item</u>	<u>Ref Designator</u>	<u>Qty</u>	<u>Part Number</u>	<u>Part Description</u>
40	R31	1	33-301415-00	RES,CC,1.5K,1W,5%
41	R33	1	34-401222-00	RES,CC,22,2W,5%
42	R35-36	2	31-402151-00	RES,MF,.51,2W,5%,200PPM
43	R26-27, R38, R43, R46, R48	6	31-403213-00	RES,CHIP,1.00K,1/8W,1%,100PPM
44	R41	1	31-403251-00	RES,CHIP,2.49K,1/8W,1%,100PPM
45	R45	1	31-403021-00	RES,10,1/8W,1%,100PPM,SMT
46	R49-52	4	31-403182-00	RES,CHIP,475,1/8W,1%,100PPM
47	R53-54	2	31-403150-00	RES,CHIP,221,1/8W,1%,100PPM
48	RT1	1	38-399841-00	THERMISTOR,5K,5%,NTC,SMT
49	U1-8	8	66-601209-00	IC,MOC3163S,OPTOTRIAC,SMT
50	U9	1	62-603399-00	IC,74HC540,SMT
51	U10, U14-15	3	62-603056-00	IC,74HC595,SHIFT_REG,SMT
52	U11	1	62-603152-00	IC,74HC14,HEX-INVERTER,SMT
53	U16-19	4	62-602996-00	IC,ULN2068B,QUAD_DRIVER
54	U20	1	62-602860-00	IC,74HC08,QUAD-AND,SMT
55	U21	1	62-603226-00	IC,74HC541
56	XF1-4	4	03-925264-01	HOLDER,FUSE
57	J52	1	51-406940-00	CONN,2PIN,PC,.165,AMP
58	C30	1	41-709269-00	CAP,1.0UF,250VAC,20%,POLY
59				
60				
61				
62				
63				
64				
65		1	12-222004-07	Screw,4-40x7/16,SST
66				
67		2	12-222006-07	Screw,6-32x7/16,SST
68		2	12-222006-14	Screw,6-32x7/8,SST
69		4	13-312006-00	Nut,Keps,6-32,SST
70		8	13-312004-00	Nut,Keps,4-40,SST
71		3	14-112006-00	Washer,Flat,#6,SST
72		1	14-998043-00	Washer,Sholder
73		1	62-899654-00	Insul,Semi,TO-220
74		A/R	88-298900-00	Heatsink Compound

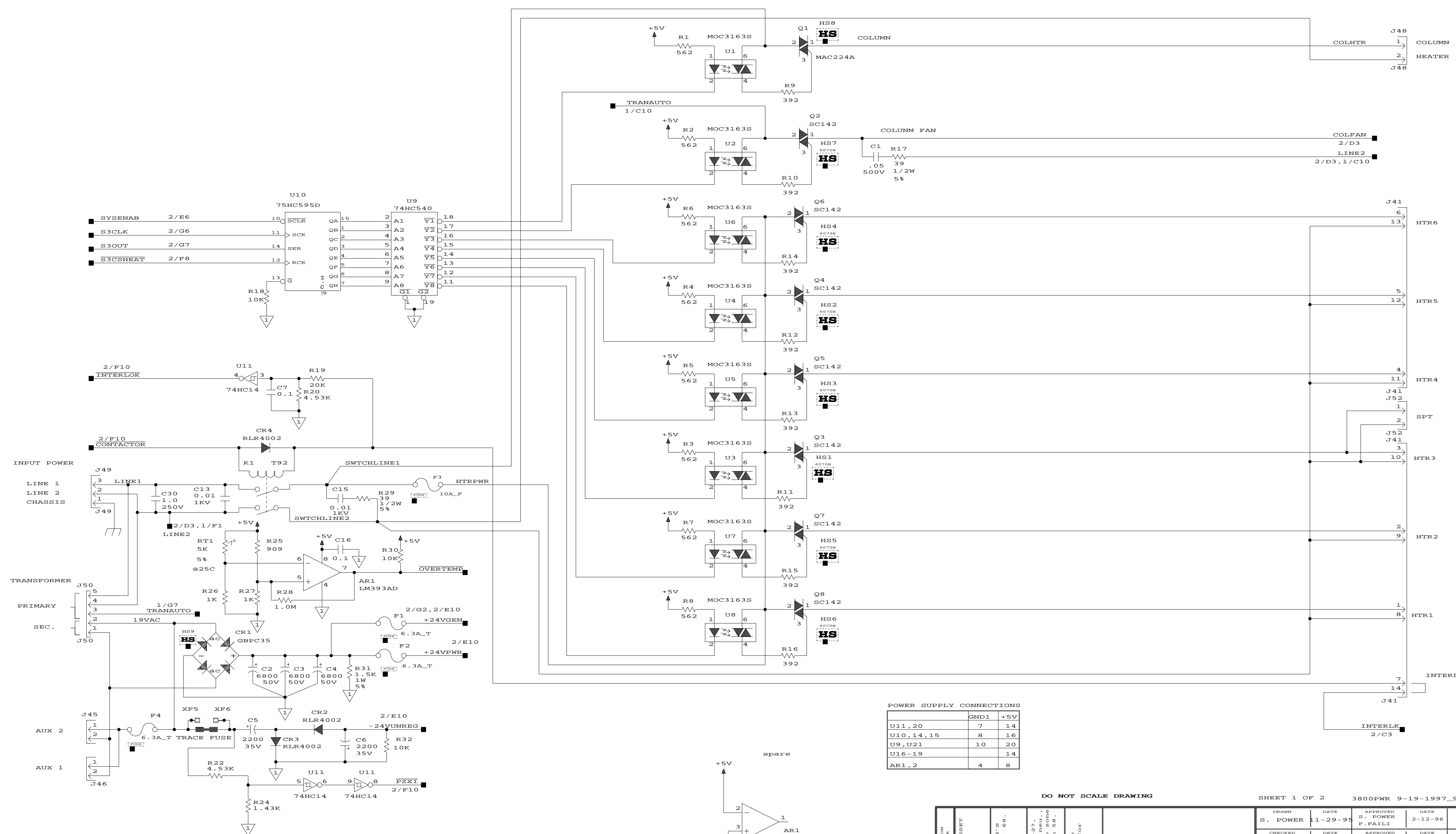

POWER SUPPLY CONNECTIONS

	GND1	+5V
U11, 20	7	14
U10, 14, 15	8	16
U9, U21	10	20
U16-19		14
AR1, 2	4	8

DO NOT SCALE DRAWING

SHEET 1 OF 2 3800PWR 9-19-1997\_9:25

- 5. ALL CAPACITORS ARE IN UF, 50V.
- 4. ALL RESISTORS ARE IN OHMS, 1/8W, 1%.
- 3. FOR A/W SEE DRAWING 03-925084-00.
- 2. FOR FAB SEE DRAWING 03-925083-00, PART 03-925083-01.
- 1. FOR ASSY. SEE DRAWING 03-925082-00, PART 03-925082-01.

NOTES: (UNLESS OTHERWISE SPECIFIED)

DESCRIPTION OF CHANGE	ADD CRVO RESET	APPROVED	DATE	CODE
	DELETE R37	S. POWER	11-29-95	F. FALLI
NUM	ADD J52	APPROVED	DATE	CLASS
	B RELEASE	S. POWER	2-9-96	R. KLEE
EO	MERC 144	19898	19963	20544
DFT	SRP	SRP	SRP	SRP
CHK	SRP	SRP	SRP	SRP
ENR	5-22-96	8-27-96	1-31-97	9-19-97
REV	1	2	3	4

change R25-27, change fan neu., move spt to cone 3, add item 39.

changed the component for U41, U47

SCHEM., P.W.A., POWER

NOT OTHERWISE SPECIFIED

varian 38 D 03-925085-00 4

DIVISION SIZE DRAWING NO. REV

11	10	9	8	7	6	5	4	3	2	1
D	03-925085-00									

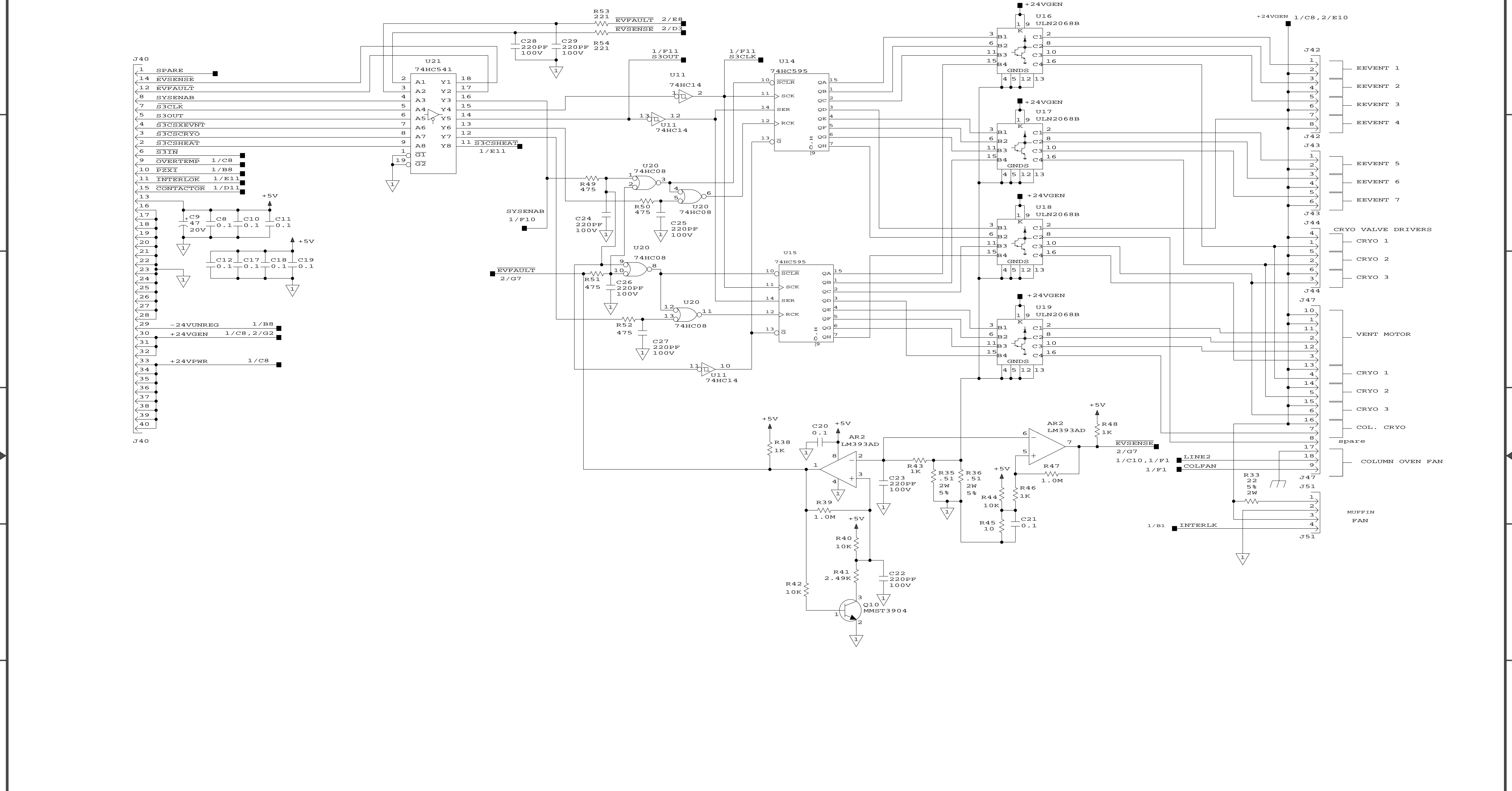

DO NOT SCALE DRAWING

SHEET 2 OF 2      3800PWR 9-19-1997\_9:25

DESCRIPTION OF CHANGE	DRAWN	DATE	APPROVED	DATE	CODE
	S. POWER	11-29-95	S. POWER	2-12-96	
	CHECKED	DATE	APPROVED	DATE	CLASS
	ST	2-9-96	S. POWER	5-22-96	
<b>SCHEM., P.W.A., POWER</b>					
NOT OTHERWISE SPECI PRAC+/- ANG+/- SCALE					
FIN. ✓ DEC .X+/- .XX+/- .XXX+/-					
38		D		03-925085-00 4	
DIVISION		SIZE		DRAWING NO. REV	